

# KENWOOD

## A907

---

HIDEAWAY TUNER AMPLIFIER

### **INSTRUCTION MANUAL**

KENWOOD CORPORATION

**Take the time to read through this instruction manual. Familiarity with installation and operation procedures will help you obtain the best performance from your new tuner amplifier.**

**For your records**

Record the serial number, found on the back of the unit, in the spaces designated on the warranty card, and in the space provided below. Refer to the model and serial numbers whenever you call upon your KENWOOD dealer for information or service on the product.

Model A907 Serial number \_\_\_\_\_



## Dear Customer:

Selecting fine audio equipment such as the unit you've just purchased is only the start of your musical enjoyment. Now it's time to consider how you can maximize the fun and excitement your equipment offers. This manufacturer and the Electronic Industries Association's Consumer Electronics Group want you to get the most out of your equipment by playing it at a safe level. One that lets the sound come through loud and clear without annoying blaring or distortion — and, most importantly, without affecting your sensitive hearing.

Sound can be deceiving. Over time your hearing "comfort level" adapts to higher volumes of sound. So what sounds "normal" can actually be loud and harmful to your hearing. Guard against this by setting your equipment at a safe level BEFORE your hearing adapts.

### To establish a safe level:

- Start your volume control at a low setting.
- Slowly increase the sound until you can hear it comfortably and clearly, and without distortion.

### Once you have established a comfortable sound level:

- Set the dial and leave it there.

Taking a minute to do this now will help to prevent hearing damage or loss in the future. After all, we want you listening for a lifetime.

## We Want You Listening For A Lifetime

Used wisely, your new sound equipment will provide a lifetime of fun and enjoyment. Since hearing damage from loud noise is often undetectable until it is too late, this manufacturer and the Electronic Industries Association's Consumer Electronics Group recommend you avoid prolonged exposure to excessive noise. This list of sound levels is included for your protection.

### Decible

#### Level Example

30	Quiet library, soft whispers
40	Living room, refrigerator, bedroom away from traffic
50	Light traffic, normal conversation, quiet office
60	Air conditioner at 20 feet, sewing machine
70	Vacuum cleaner, hair dryer, noisy restaurant
80	Average city traffic, garbage disposals, alarm clock at two feet.

### THE FOLLOWING NOISES CAN BE DANGEROUS UNDER CONSTANT EXPOSURE

90	Subway, motorcycle, truck traffic, lawn mower
100	Garbage truck, chain saw, pneumatic drill
120	Rock band concert in front of speakers, thunderclap
140	Gunshot blast, jet plane
180	Rocket launching pad

Information courtesy of the Deafness Research Foundation.



# Safety precautions

## **▲WARNING**

### ***To prevent injury and/or fire, take the following precautions:***

- Ensure that the unit is securely installed. Otherwise it may fly out of place during collisions and other jolts.
- When extending the ignition, battery or ground cables, make sure to use automotive-grade cables or other cables with an area of 0.75mm<sup>2</sup> (AWG18) or more to prevent cable deterioration and damage to the cable coating.
- To prevent short circuits, never put or leave any metallic objects (e.g., coins or metal tools) inside the unit.
- If the unit starts to emit smoke or strange smells, turn off the power immediately and consult your Kenwood dealer.

## **▲CAUTION**

### ***To prevent damage to the machine, take the following precautions:***

- Make sure to ground the unit to a negative 12V DC power supply.
- Do not open the top or bottom covers of the unit.
- Do not install the unit in a spot exposed to direct sunlight or excessive heat or humidity. Also avoid places with too much dust or the possibility of water splashing.
- When replacing a fuse, only use a new one with the prescribed rating. Using a fuse with the wrong rating may cause your unit to malfunction.
- To prevent short circuits when replacing a fuse, first disconnect the wiring harness.
- During installation, do not use any screws except for the ones provided. The use of improper screws might result in damage to the main unit.
- When drilling a hole in the car to fix the brackets, make sure not to damage the fuel tank, brake tube, wiring harnesses, etc. on the other side.

## **NOTE**

If you experience problems during installation, consult your Kenwood dealer.

### ***Cleaning the Unit***

If the surface is dirty, wipe it clean with a silicon cloth or soft dry cloth with the power off.

## **▲CAUTION**

Do not use hard cloths or paint thinner, alcohol, or other volatile solvents.

### ***Audio systems for controlling this set***

This set is operated with a control unit, and does not have its own controls.

The set can be operated with the following control units (as of May 1998):

VZ907

### **FCC WARNING**

This equipment may generate or use radio frequency energy. Changes or modifications to this equipment may cause harmful interference unless the modifications are expressly approved in the instruction manual. The user could lose the authority to operate this equipment if an unauthorized change or modification is made.

# Installation

## ■ Accessories

### External view

..... Number of items



.....2



.....2

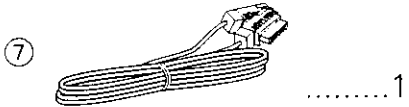

.....1

### External view

..... Number of items

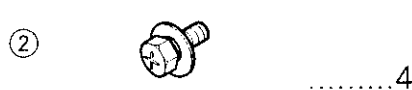

.....4

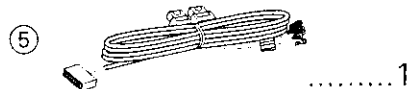

.....1

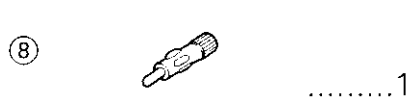

.....1

### External view

..... Number of items



.....4

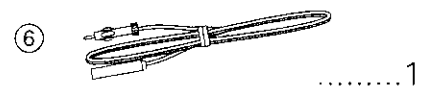

.....1

### ▲CAUTION

The use of any accessories except for those provided might result in damage to the unit. Make sure only to use the accessories shipped with the unit, as shown above.

## ■ Installation Procedure

1. To prevent a short circuit, remove the key from the ignition and disconnect the ⊖ battery.
2. Make the proper input and output wire connections for each unit.
3. Connect the speaker wires of the wiring harness.
4. Connect the wiring harness wires in the following order: ground, battery, ignition.
5. Connect the wiring harness connector to the unit.
6. Install the unit in your car.
7. Reconnect the ⊖ battery.
8. Press the reset button.

### ▲CAUTION

- If your car's ignition does not have an ACC position, connect the ignition wires to a power source that can be turned on and off with the ignition key. If you connect the ignition wire to a power source with a constant voltage supply, as with battery wires, the battery may die.
- If the fuse blows, first make sure the wires aren't touching to cause a short circuit, then replace the old fuse with one with the same rating.
- Do not let unconnected wires or terminals touch metal on the car or anything else conducting electricity. To prevent a short circuit, do not remove the caps on the ends of the unconnected wires or the terminals.
- Connect the speaker wires correctly to the terminals to which they correspond. The unit may be damaged or fail to work if you share the ⊖ wires or ground them to any metal part in the car.
- After the unit is installed, check whether the brake lamps, blinkers, wipers, etc. on the car are working properly.
- Insulate unconnected wires with vinyl tape or other similar material.
- Thoroughly wipe away oil and other dirt from the installation surface. Please avoid installation on uneven surfaces.
- During use, the surface temperature of this unit will become high, therefore it should not be mounted where anything sensitive to the heat, such as people or resins, would come into contact with it.
- Do not install the unit under the carpet. Otherwise heat build-up occurs and the unit may be damaged.
- Install this unit in a location which allows heat to easily dissipate. Once installed, do not place any object on top of the unit.
- Install the unit securely in a location that does not interfere with driving.

# Installation

## ■ Installation for Hideaway unit

### ● Securing to audio board

1 Attach the installation brackets to the sides of the hideaway unit using the sems bolts (M4x8mm).

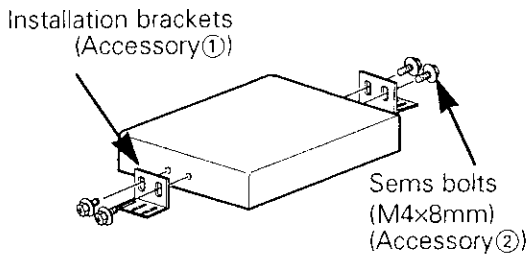

2 Use the tapping screw (ø4x16mm) to secure the hideaway unit to the audio board.

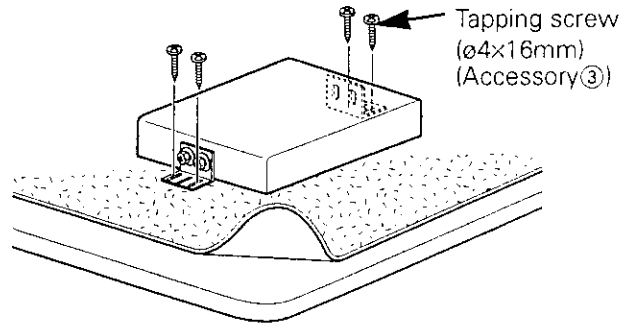

### ● Securing to pile carpet

Peel the protective strips off of the velcro strips, attach them to the bottom of the hideaway unit, and secure to the pile carpet.

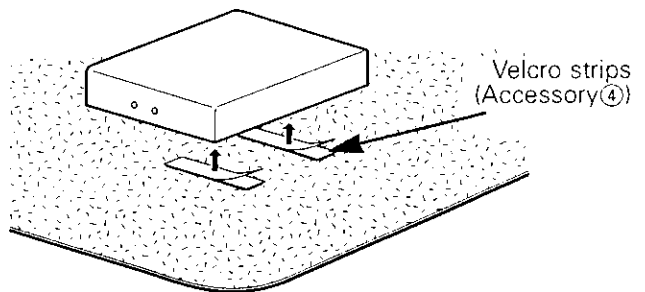

### ▲ CAUTION

Please do not install the unit near the dashboard, the rear tray, or other important components. Doing so could lead to injury or accident should the unit come off due to a shock and strike a person or an important component. Tapping screws should be used for mounting. (Attachment with velcro strips, although easy, can come off with a shock.)

# Installation

## ■ Connecting Wires to Terminals

### ▲WARNING

If you connect the ignition wire (red) and the battery wire (yellow) to the car chassis (ground), you may cause a short circuit, that in turn may start a fire. Always connect those wires to the power source running through the fuse box.

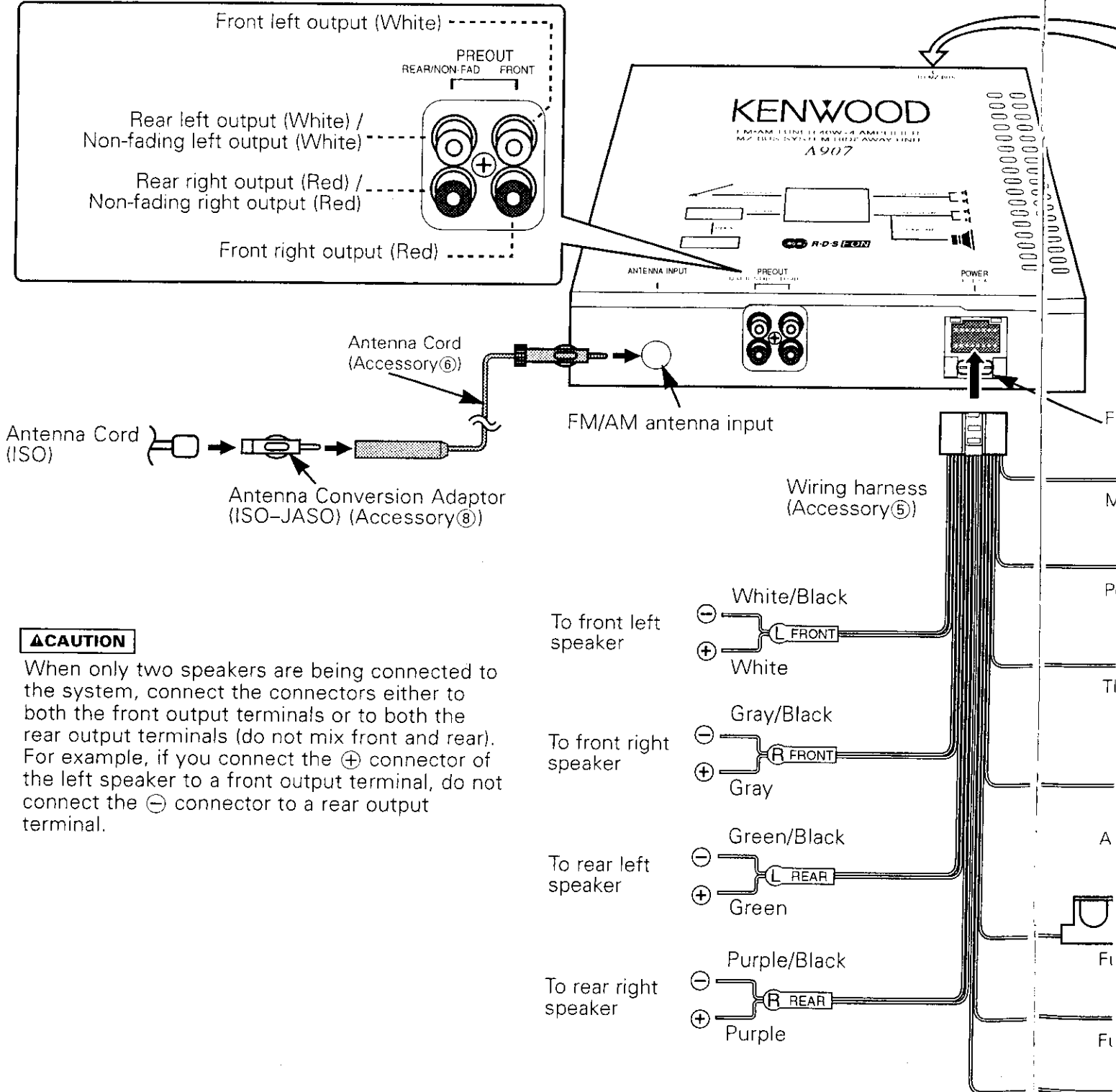

### ▲CAUTION

When only two speakers are being connected to the system, connect the connectors either to both the front output terminals or to both the rear output terminals (do not mix front and rear). For example, if you connect the ⊕ connector of the left speaker to a front output terminal, do not connect the ⊖ connector to a rear output terminal.

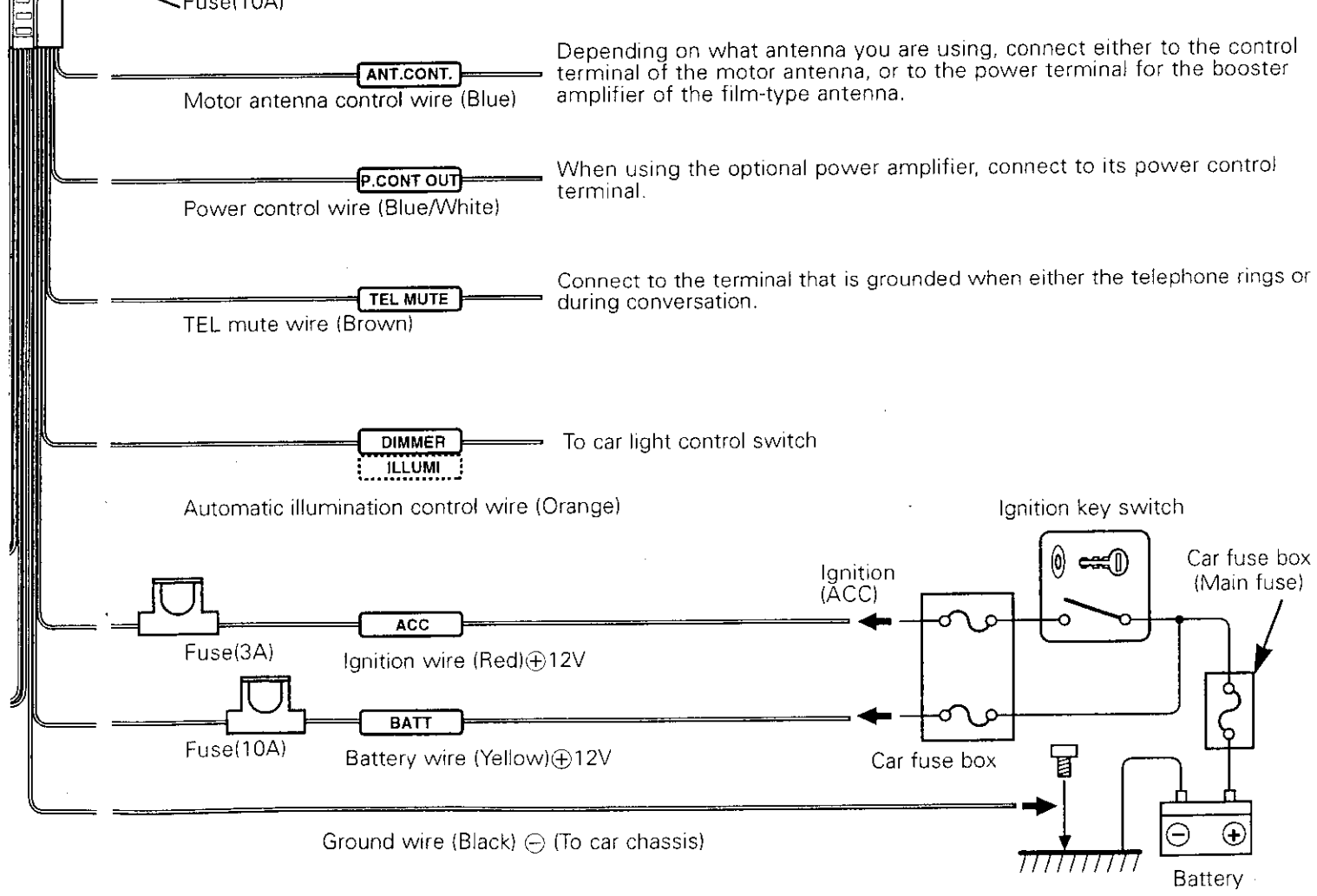
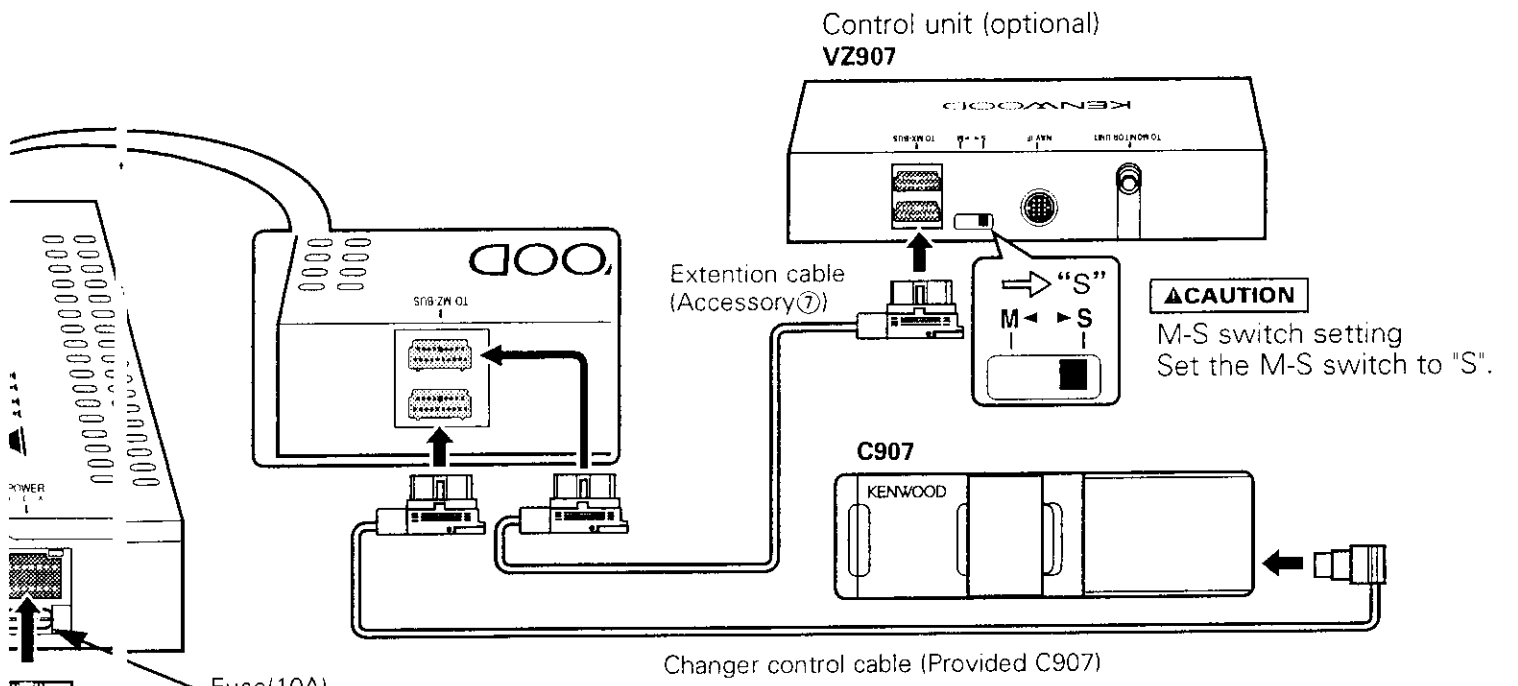

# Troubleshooting Guide

**What might appear to be a malfunction in your unit may just be the result of slight misoperation or miswiring. Before calling service, first check the following table for possible problems.**

PROBLEM	POSSIBLE CAUSE	SOLUTION
The power does not turn on.	The fuse has blown.	After checking for short circuits in the cables, replace the fuse with one having the same rating.
No sound can be heard, or the volume is low.	<ul style="list-style-type: none"> <li>• The Attenuator function is turned on.</li> <li>• The fader and/or balance settings are set all the way to one side.</li> <li>• The input/output cables or wiring harness are connected incorrectly.</li> </ul>	<ul style="list-style-type: none"> <li>• Turn off the Attenuator function.</li> <li>• Reset the fader and/or balance settings.</li> <li>• Reconnect the input/output cables and/or the wiring harness correctly. See the section on "Connecting Wires to Terminals".</li> </ul>
Nothing happens when the buttons are pressed.	The computer chip in the unit is not functioning normally.	Press the reset button on the unit
The sound quality is poor or distorted.	<ul style="list-style-type: none"> <li>• A speaker cable may be pinched by a screw in the car.</li> <li>• The speakers are not wired correctly.</li> </ul>	<ul style="list-style-type: none"> <li>• Check the speaker wiring..</li> <li>• Reconnect the speaker cables so that each output terminal is connected to a different speaker.</li> </ul>
Radio reception is poor.	<ul style="list-style-type: none"> <li>• The car antenna is not extended.</li> <li>• The antenna control cable is not connected.</li> </ul>	<ul style="list-style-type: none"> <li>• Pull out the antenna all the way.</li> <li>• Connect the cable correctly, referring to the section on "Connecting Wires to Terminals".</li> </ul>
The memory is erased when the ignition is turned off.	<ul style="list-style-type: none"> <li>• The battery cable has not been connected to the proper terminal.</li> <li>• The ignition and battery cable are incorrectly connected.</li> </ul>	<ul style="list-style-type: none"> <li>• Connect the cable correctly, referring to the section on "Connecting Wires to Terminals".</li> <li>• Connect the cable correctly, referring to the section on "Connecting Wires to Terminals".</li> </ul>

**The following indications are used to inform you that there is a problem with the connections of the system.**

BUS-E01: The M-S switch of the TV monitor connected to the BUS terminal is set to "M".  
⇒ Switch the TV monitor's M-S switch to "S".

BUS-E50: Two or more center units are connected.

BUS-W02: The No. switch of the connected disc changers is set to the same number (1 or 2) for both units.  
⇒ Set the No. switch of one disc changer to "1" and the other unit to "2" to enable proper use.

BUS-W08: Two or more TV monitors are connected to the BUS terminal.



# Specifications

Specifications subject to change without notice.

## **FM tuner section**

Frequency range (200 kHz Space) .....	87.9 MHz – 107.9 MHz
Usable sensitivity (S/N = 30 dB) .....	9.3 dBf (0.8 $\mu$ V/75 $\Omega$ )
Quieting Sensitivity (S/N = 50 dB) .....	15.2 dBf (1.6 $\mu$ V/75 $\Omega$ )
Frequency response ( $\pm$ 3.0 dB) .....	30 Hz – 15 kHz
Signal to Noise ratio (MONO) .....	70 dB
Selectivity ( $\pm$ 400 kHz) .....	$\geq$ 80 dB
Stereo separation (1 kHz) .....	40 dB

## **AM tuner section**

Frequency range (10 kHz space).....	530 kHz – 1700 kHz
Usable sensitivity .....	28 dB (25 $\mu$ V)

## **Audio section**

Maximum output power .....	40 W $\times$ 4
Full bandwidth power (at less than 1 % THD) .....	22 W $\times$ 4
Tone action	
Bass:.....	100 Hz $\pm$ 10 dB
Treble: .....	10 kHz $\pm$ 10 dB
Preout level / load .....	4 V / 10 k $\Omega$ (during disc play)
Preout Impedance .....	$\leq$ 80 $\Omega$

## **General**

Operating voltage .....	14.4 V (11 – 16 V allowable)
Current consumption .....	10 A at Rated power
Installation size (W $\times$ H $\times$ D) .....	213 $\times$ 40 $\times$ 148 mm
	8-3/8 $\times$ 1-9/16 $\times$ 5-13/16 in.
Weight .....	960 g
	2.1 LBS